



AUGSUT 1, 2019

GSCCCA UCC FILE XML GUIDE

WILLIAMS, CHAS

GEORGIA SUPERIOR COURT CLERKS' COOPERATIVE AUTHORITY

<https://gsccca.org>

REVISION HISTORY

Revision	Description	Date
1	Initial Version	08/01/2019

CONTENTS

Revision History	1
UCC eFile Public API	3
Schema Definitions	4
Document	4
Version	4
Header	5
Test	5
Filer	6
Names	7
Individual Name	8
Record	9
Collateral	11
Acknowledgement	12
Appendix A – Enumerations	14
TransType	14
AmendmentType	14
AmendmentAction	15
Status	16
MIMEtype	16
Appendix B – UCC Filing Types	17
Appendix C – Validation, Parsing, and Data Requirements	18
Official UCC Form	18
Element and Attribute Requirements	18
Callbacks	18
Maximum Payload	18

UCC EFILE PUBLIC API

The Georgia Superior Court Clerks' Cooperative Authority offers a public Simple Object Access Protocol (SOAP) API that allows the submission, payment, and processing of UCC Filings. Filers may use this system in order to submit and pay for UCCs that are then processed by county users, either to accept or reject the filing on their end.

To make use of this document, first read the GSCCCA UCC eFiling Filer Implementation Guide found on <https://efiledev.gsccca.org/Implementers.aspx>.

The UCC GSCCCA File XML Guide details the modified IACA File XML schema that is used to submit new UCCs as well as transfer details on recording and acknowledgement information.

ASSUMPTIONS

This is a technical document intended for developers and service providers who wish to utilize the UCC eFile API programmatically. Anyone reading this document should be well versed in XML and XSDs, as well as have knowledge on how to connect to a SOAP web service to make calls and process responses. Expectations are that readers will be familiar with the basics of the IACA File XML and IACA Status and Receipt XML formats. Lastly, familiarity with UCCs and Georgia's laws will be beneficial.

XML SCHEMA

The XSD file defining the IACA File XML schema can be downloaded on the Implementer's page linked above under the UCC eFiling Related Files heading.

GSCCCA UCC EFILE API

This schema is used in the public eFile API for the purposes of submission of new filings and the retrieval of modifications based on county processing (acceptance or rejection). Once submitted, the only time the filing will be modified is by the county for processing purposes or through resubmittal of a rejected filing.

SCHEMA DEFINITIONS

This XML schema is based on the IACA Receipt and Status XML schema with a few modifications. Use these definitions along with the downloadable XSD to ensure compatibility in your system.

In the element and attribute lists, description will give any basic details of utilization, attribute value will detail any formatting requirements, and length will specify maximum possible size.

DOCUMENT

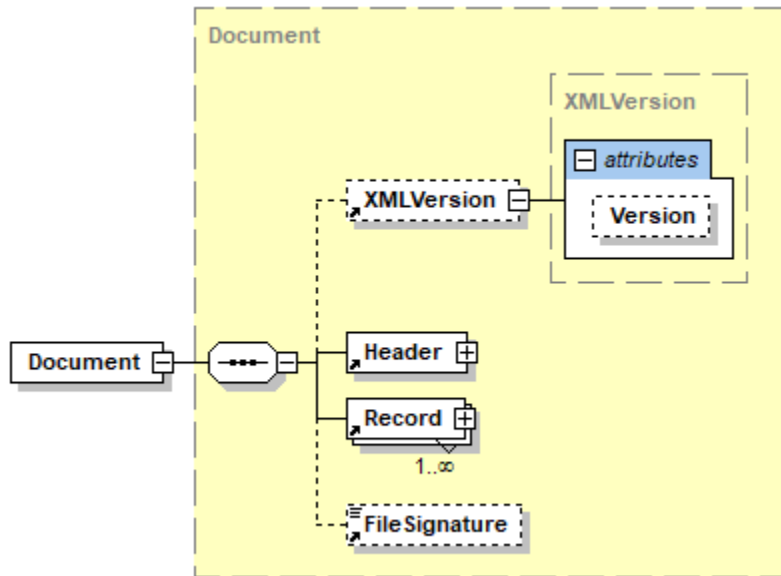

The Document element is the root element of the GSCCCA File XML. It contains the XMLVersion, Header, and Record elements. The FileSignature element is ignored the GSCCCA.

The Only one UCC, and thus Record element, can be included in a single submission. If more than one Record element is included, an error will be returned by the eFile system.

Element	Description	Attribute value	Length	Occurrence
Document	Root element of the XML		n/a	1
XMLVersion	Contains schema version		n/a	Optional Max 1
Header	Contains Filer Information		n/a	1
Record	Contains UCC Information		n/a	1
FileSignature	Ignored by GSCCCA		n/a	0

VERSION

Attribute	Description	Attribute value	Length	Occurrence
XMLVersion/@Version	Must be 02162013		50	1

HEADER

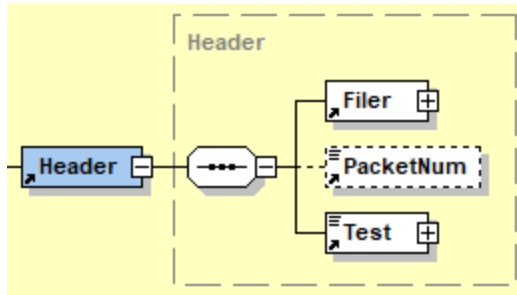

The header contains all non-document related information for the UCC. This includes information on the filer as well a packet number supplied by the filer that will be included.

Element	Description	Attribute value	Length	Occurrence
Filer	Contains Filer Details		n/a	1
PacketNum	Identifier used by the Filer		32	1
Test	Designates Test UCC Note: GSCCCA does not utilize this field to allow testing. For testing, use the development/test site		n/a	1

TEST

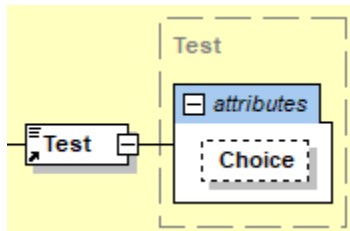

The Test element is not currently utilized by the GSCCCA. As such, it must always indicate "Y" to denote that it is not a test. For all tests, please use the development/test eFile website. Information on testing can be found in the GSCCCA UCC API Filer Implementation Guide on the Implementer's page of the eFile website.

Attribute	Description	Attribute value	Length	Occurrence
Test/@Choice	Must be "Y"		1	1

FILER

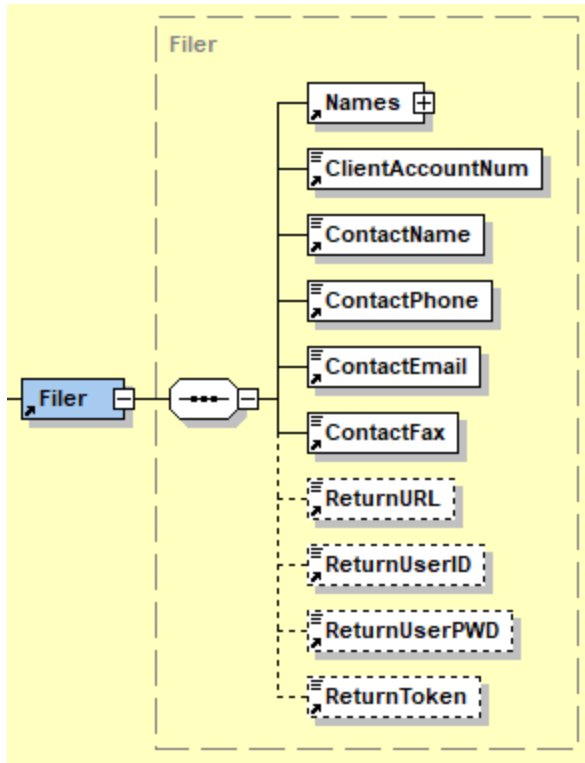

Filer information is included here. When the filing originates on the eFile website, and not through the UCC eFile API, then this information will be pulled from the forms filled out by the filer when creating or editing their account information.

Element	Description	Attribute value	Length	Occurrence
Names	Contains various identifying information for the Filer		n/a	1
ClientAccountNum	Account number of filer. If this originates from GSCCCA, it will be a GUID		36	1
ContactName	Name of contact for filing		35	1
ContactPhone	Phone of contact for filing		50	1
ContactEmail	Email of contact for filing		256	1
ContactFax	Fax of contact for filing		16	1
ReturnURL	URL used for callback sent by the GSCCCA on processing	See Appendix C	100	Optional Max 1
ReturnUserID	Ignored by GSCCCA		n/a	Optional Max 1
ReturnUserPWD	Ignored by GSCCCA		n/a	Optional Max 1
ReturnToken	Unique identifying token set by submitter for use authenticating callback	See Appendix C	255	Optional Max 1

NAMES

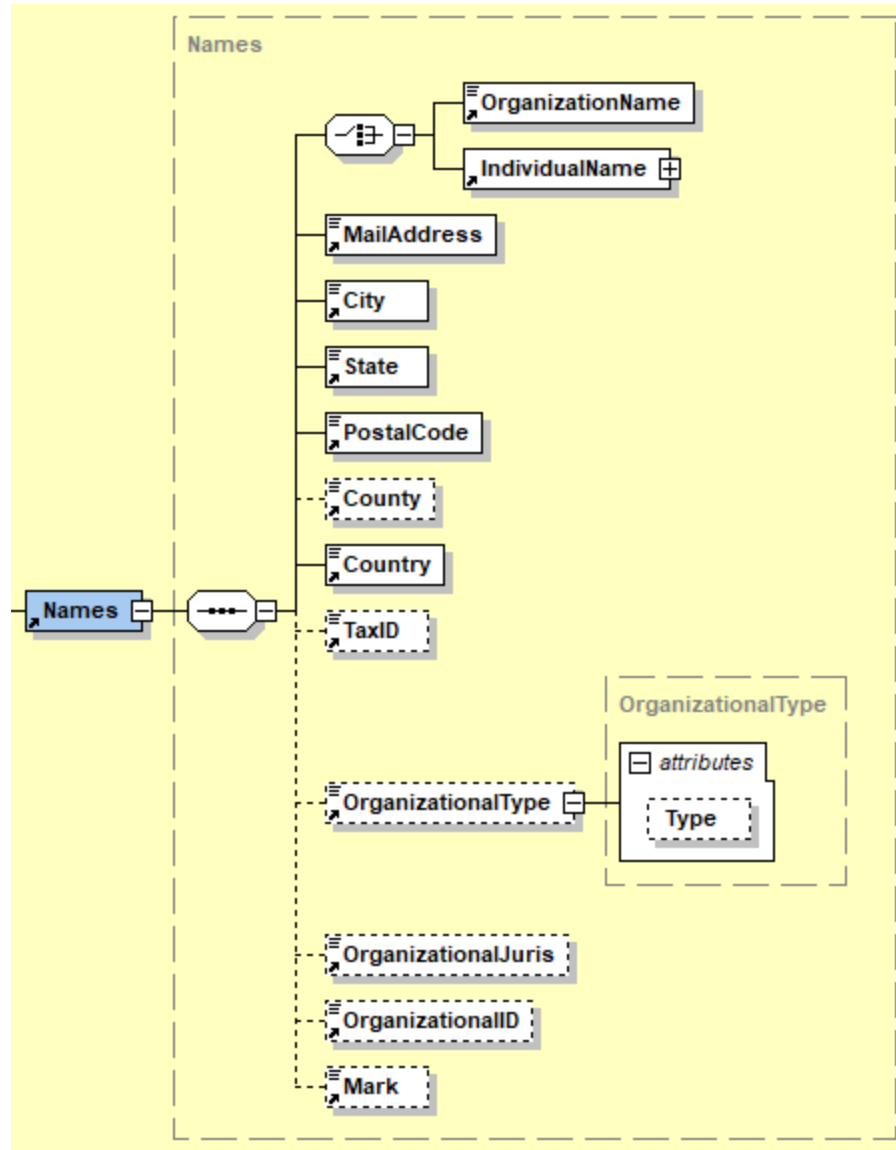

The names field contains more details on the filer. Several elements are not currently used by the GSCCCA and will be ignored by the system.

Tax IDs must not be included in the submission. If included, the eFile system will return an error.

If the filer is an organization, then OrganizationName must be included, otherwise IndividualName must be included. There is never a time when both of these elements can be included at the same time.

Element	Description	Attribute value	Length	Occurrence
OrganizationName	Name of the filing organization Note: exclusive with IndividualName		50	Optional Max 1
IndividualName	Container for individual name Note: exclusive with OrganizationName		n/a	Optional Max 1
MailAddress	Street address line item		50	1
City	City line item		50	1
State	State line item		3	1
PostalCode	Zip/Postal code line item		10	1

County	County line item		100	1
Country	Country Code line item		4	1
TaxID	Must be excluded		n/a	0
OrganizationalType	Ignored by GSCCCA		n/a	Optional Max 1
OrganizationalJuris	Ignored by GSCCCA		n/a	Optional Max 1
OrganizationalID	Ignored by GSCCCA		n/a	Optional Max 1
Mark	Ignored by GSCCCA		n/a	Optional Max 1

Attribute	Description	Attribute value	Length	Occurrence
OrganizationalType/@Type	Ignored by GSCCCA		n/a	n/a

INDIVIDUAL NAME

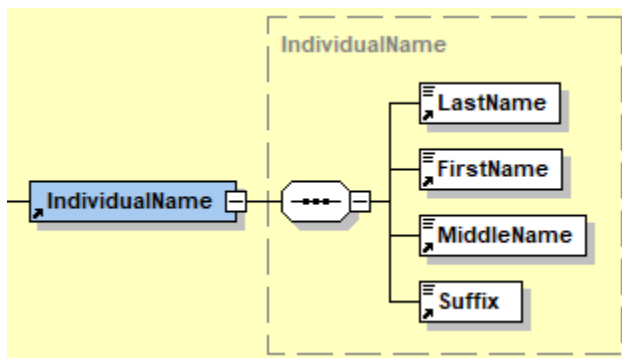

If the filer is an individual and not an organization, these elements will record the filer's name.

Element	Description	Attribute value	Length	Occurrence
LastName	Surname of filer (not necessarily last name)		50	1
FirstName	Given name of filer (not necessarily first name)		50	1
MiddleName	Other names		50	1
Suffix	Name modifiers		50	1

RECORD

The record element contains all relevant filing information about the UCC.

See Appendix A for information on the allowed values for TransType, AmendmentType, and AmendmentAction. See Appendix B for information on how the GSCCCA interprets and will submit UCCs based on how these values are set at the time of submission.

SubmitterRef is a required field, and it must be a unique value. It will be used to ensure that a filer does not accidentally submit the same UCC multiple times as a protective measure to prevent the accidental filing of documents.

DocumentReceiptID is assigned the value of the Filing ID, which can be found on the eFile website dashboard as the identifier of all UCCs filed. This value will be necessary to perform future actions and will be returned the filer upon initial submission.

FileInRealEstate is not allowed by the GSCCCA. If a filer wishes to file a real estate document, then the real estate eFile API must be used.

Collateral can be used to attach collateral documents to the UCC that will be recorded as part of the filing. These must be base64 string encoded. For more information on attachments and data requirements see Appendix C.

Acknowledgement is for use only by the county of recording. When accepted or rejected, values here will be populated.

All other elements are ignored by the GSCCCA.

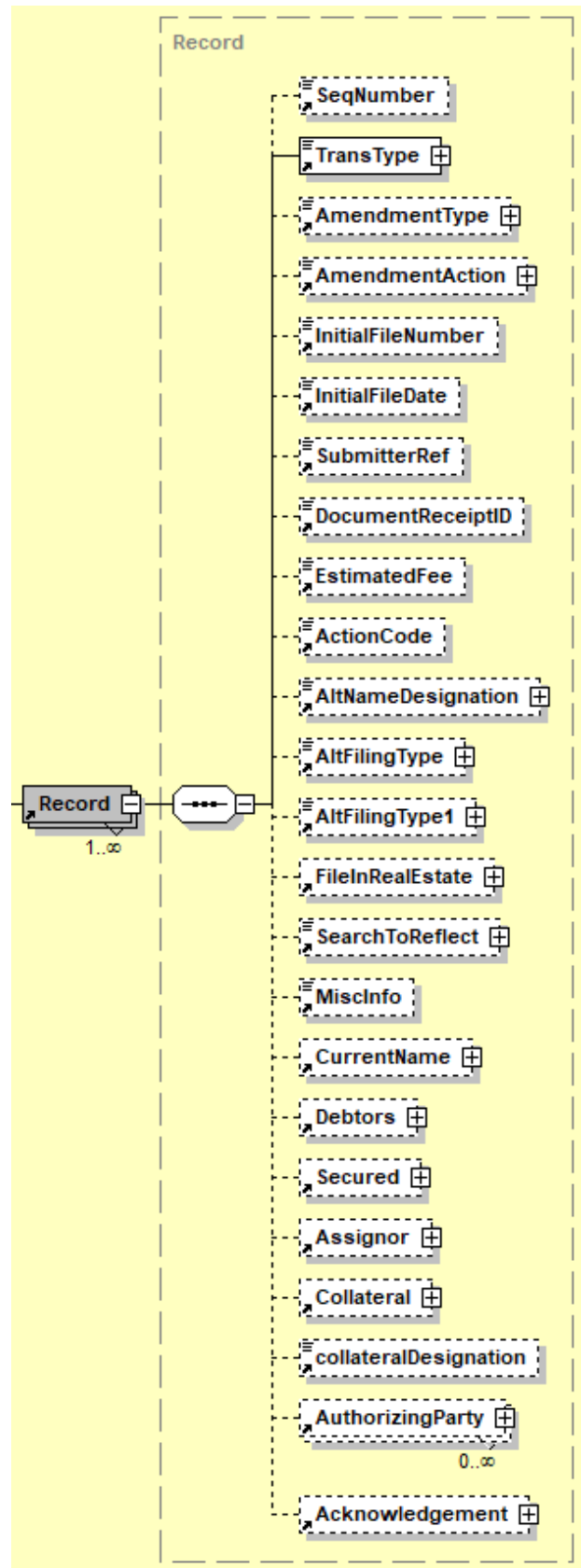

Element	Description	Attribute value	Length	Occurrence
SeqNumber	Any value		5	1
Transtype	See Type attribute listed below in next section	See Appendix B	n/a	Optional Max 1
AmendmentType	See Type attribute listed below in next section	See Appendix B	n/a	Optional Max 1
AmendmentAction	See Action attribute listed below in next section	See Appendix B	n/a	Optional Max 1
InitialFileNumber	Ignored by GSCCCA		n/a	n/a
InitialFileDate	Ignored by GSCCCA		n/a	n/a
SubmitterRef	Filer Reference required		80	1
DocumentReceiptID	ID added by GSCCCA after submission		10	Optional Max 1
EstimatedFee	Included by GSCCCA after submission Note: value does not include processing fees based on payment method	###.##	10	Optional Max 1
ActionCode	Ignored by GSCCCA		n/a	n/a
AltNameDesignation	Ignored by GSCCCA		n/a	n/a
OrganizationalID	Ignored by GSCCCA		n/a	n/a
AltFilingType	Ignored by GSCCCA		n/a	n/a
AltFilingType1	Ignored by GSCCCA		n/a	n/a
FileInRealEstate	If included will cause error. Note: Use GSCCCA Real Estate eFile API		n/a	0
SearchToReflect	Ignored by GSCCCA		n/a	n/a
MiscInfo	Ignored by GSCCCA		n/a	n/a
CurrentName	Ignored by GSCCCA		n/a	n/a
Debtors	Ignored by GSCCCA		n/a	n/a
Secured	Ignored by GSCCCA		n/a	n/a
Assignor	Ignored by GSCCCA		n/a	n/a
Collateral	Container element for collateral information.	See Appendix C	n/a	Optional Max 1
collateralDesignation	Ignored by GSCCCA		n/a	n/a
AuthorizingParty	Ignored by GSCCCA		n/a	n/a
Acknowledgement	Container element for recording data. Note: populated on acceptance or rejection by county of recording.		n/a	Optional Max 1

COLLATERAL

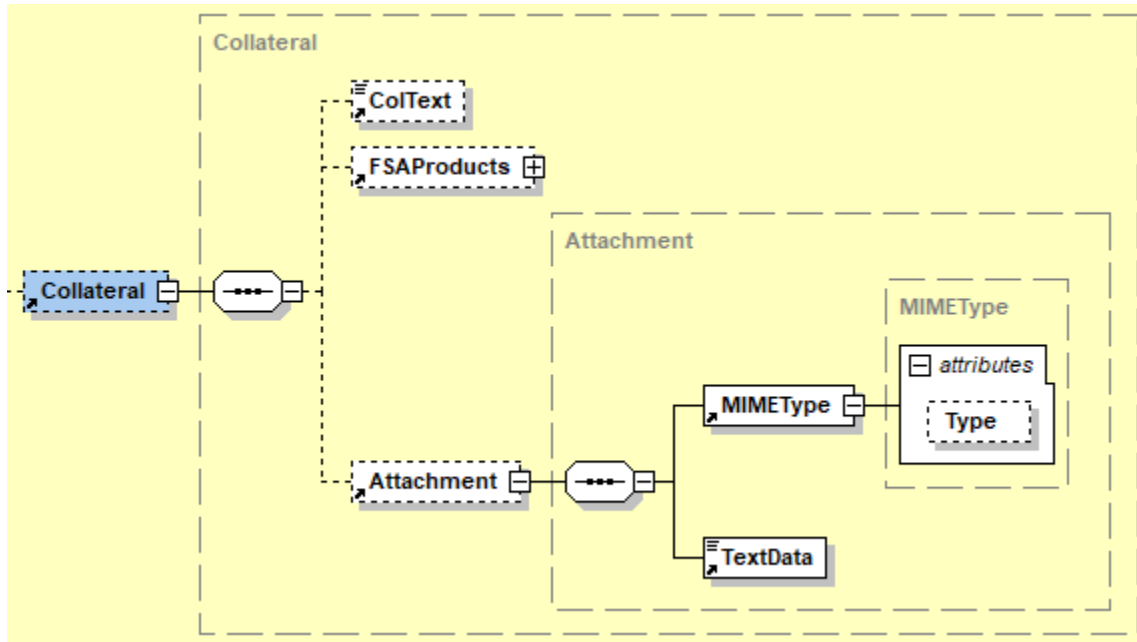

Element	Description	Attribute value	Length	Occurrence
ColText	Ignored by GSCCCA		n/a	
FSAProducts	Ignored by GSCCCA		n/a	
Attachment	Contains any encoded PDF collateral document(s)		n/a	Optional Max 1
MIMETYPE	See Type attribute below		n/a	1
TextData	Base64 string encoding a collateral PDF attachment. Note: Will be stamped and included with final UCC filing		See Appendix C	1

Attribute	Description	Attribute value	Length	Occurrence
Type	Must be "PDF"	See Appendix A	n/a	1

ACKNOWLEDGEMENT

The Acknowledgement section is for use by the recording county only.

This section contains recording information, such as file number, book, page, date, and fees. It also will contain rejection information in cases where the UCC is rejected, using the Errors section.

The FileStatus uses various GSCCCA status values necessary to convey the Georgia designated workflow. These are defined in Appendix A.

The format for filing numbers in Georgia are CCC-YYY-##### where CCC is the numerical county designation, YYYY is the year of recording, and ##### forms a unique series.

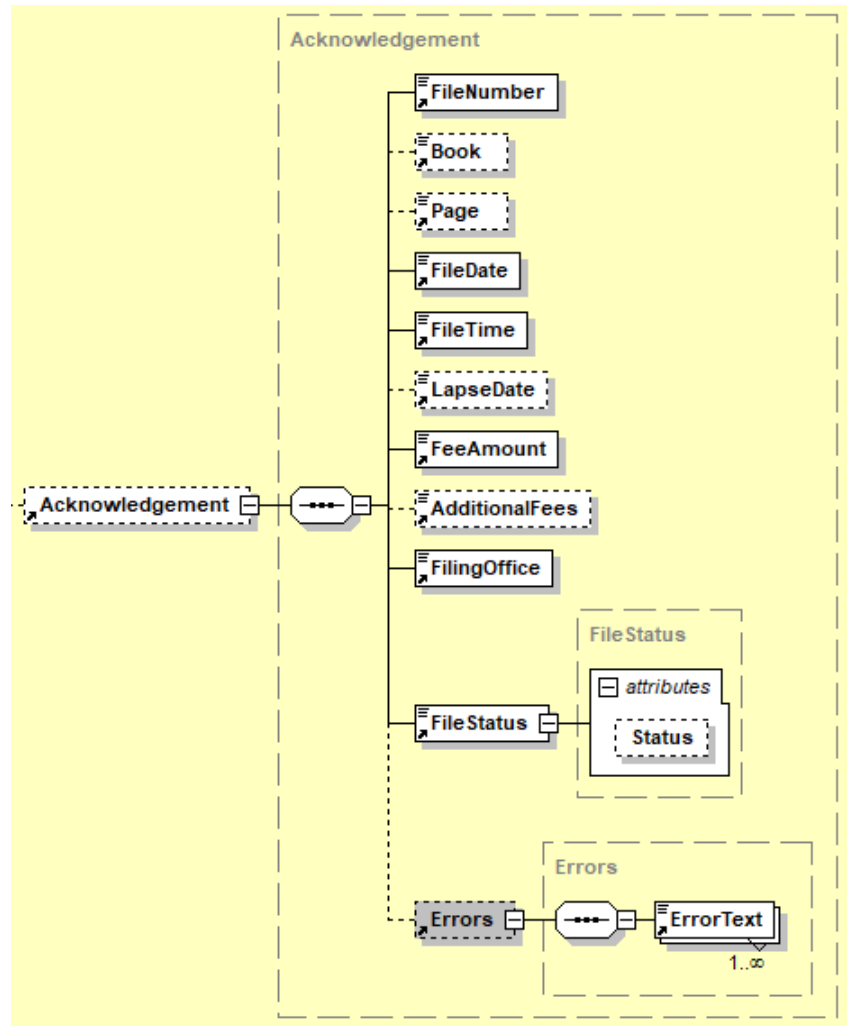

Element	Description	Attribute value	Length	Occurrence
FileNumber	File number assigned to UCC at time of acceptance	CCC-YYYY-#####	24	1
Book	If the county assigns a book, it will be included here		6	Optional Max 1
Page	If the county assigns a page, it will be included here		5	Optional Max 1
FileDate	Date filing was processed	DD/MM/YYYY	10	1
FileTime	Time filing was processed	##:## AM/PM		1
LapseDate	Ignored by GSCCCA		n/a	0
FeeAmount	Fee charged by county	###.##	10	1
AdditionalFees	Any processing fees will be included here if applicable	###.##	10	0
FilingOffice	The county of recording		100	1

FileStatus	Status of the filing		n/a	1
Errors	If the UCC is rejected, contains error text that describes the reason(s) for rejection		n/a	Optional Max 1
ErrorText	Reason(s) for rejection		100	1 or more

Attribute	Description	Attribute value	Length	Occurrence
FileStatus/@Status	Status in GSCCCA workflow	See Appendix A	n/a	1

APPENDIX A – ENUMERATIONS

Below are listed all enumerations parsed used by the GSCCCA when processing a UCC.

TRANSTYPE

Used to help determine what type of UCC (UCC-1, UCC-1As, UCC-3, or UCC-5) is being filed. See Appendix B for more details on how this value is determined.

Recording

TransType

Type

Initial

Amendment

AMENDMENTTYPE

Used to help determine what type of UCC (UCC-1, UCC-1As, UCC-3, or UCC-5) is being filed. See Appendix B for more details on how this value is determined.

Recording

AmendmentType

Type

TerminationSecuredParty

Assignment

Continuation

TerminationDebtor

Correction

AmendmentParties

AmendmentCollateral

OfficerStatement

InformationStatement

UnknownType

NoType

AMENDMENTACTION

Used to help determine what type of UCC (UCC-1, UCC-1As, UCC-3, or UCC-5) is being filed. See Appendix B for more details on how this value is determined.

Recording

AmendmentAction

Action SecuredPartyChange

SecuredPartyAdd

DebtorAdd

SecuredPartyDelete

CollateralChange

DebtorDelete

CollateralAdd

CollateralDelete

CollateralAssign

CollateralRestate

DebtorChange

UnknownAction

NOAction

STATUS

Indicates where the UCC is in the eFile workflow.

Acknowledgement

Status

value	AcceptedWithErrors
	Rejected
	Accepted
	AwaitingPayment
	Resubmitted
	Cancelled
	AwaitingClerkReview
	Incomplete
	FailedToStamp
	NOStatus

MIMETYPE

Used by the GSCCCA to determine how to decode and read attached files.

Attahment

MIMETYPE

Type	PDF
------	-----

APPENDIX B – UCC FILING TYPES

In order to determine the type of filing submitted, the GSCCCA parses three enumerations (TransType, AmendmentType, and AmendmentAction). In order to help facilitate quick and accurate processing by the county, please ensure that these values as assigned match as expected the filed PDF UCC filing attached to the submission itself.

UCC Form	TransType	AmendmentType	AmendmentAction
UCC-1	Initial	NOType	NOAction
UCC-1As	Initial	Assignment	NOAction
UCC-3	Amendment	AmendmentCollateral, AmmendmentParties, Assignment, Continuation, TerminationDebtor, TerminationSecuredParty, UnknownType	DebtorAdd, DebtorChange, DeptorDelete, SecuredPartyAdd, SecuredPartyChange, SecuredPartyDelete, CollateralAdd, CollateralDelete, CollateralRestate, CollateralAssign, UnknownAction
UCC-5	Amendment	InformationStatement	NOAction

UnknownType and UnknownAction are for use only by the GSCCCA and cannot be used for submissions through the API. They exist for the creation of XML from UCC submissions through the GSCCCA eFile website where these values are not included in the submission. Below is a mapping of values to numbers locations on UCC Forms.

	#	DebtorAdd	DebtorChange	DebtorDelete	SecuredPartyAdd	SecuredPartyChange	SecuredPartyDelete	CollateralAdd	CollateralDelete	CollateralRestate	CollateralAssign	NOAction
AmendmentCollateral	8							✓	✓	✓	✓	
AmmendmentParties	5	✓	✓	✓	✓	✓	✓					
Assignment	3											✓
Correction†	n/a											
Continuation	4											✓
TerminationDebtor	2											✓
TerminationSecuredParty	2											✓
OfficerStatement†	n/a											
InformationStatement ††												✓
NOType †††	n/a											✓

† Correction and OfficerStatement will generate an error response.

†† InformationStatement will indicate a UCC-5

††† NOType only applies to the UCC-1 form

APPENDIX C – VALIDATION, PARSING, AND DATA REQUIREMENTS

Upon submission of a UCC, the eFile system will validate your XML against this schema and parse relevant values.

OFFICIAL UCC FORM

The XML data does not currently define the official UCC document, as the GSCCCA eFile system utilizes a Level-2 transfer system. This means that the filled out PDF form that is sent alongside the GSCCCA File XML is the official UCC document while the XML is used by the system to parse data and make determinations about the submission such as the UCC type.

ELEMENT AND ATTRIBUTE REQUIREMENTS

Several elements in the XML schema are not directly defined in this document. Either they are listed as "Ignored by GSCCCA," "Must be <value>," or they explicitly will give an error in certain cases or if included.

IGNORED BY GSCCCA

Elements and Attributes that are designated as ignored by the GSCCCA are included in this XML schema for potential forward compatibility. At the moment, validation checks to ensure that the submitted XML conforms to the XSD, but no checks is made that the data is usable.

MUST BE...

Some element or attributes have required values. The system will ensure that these elements or attributes conform to the system's expectations and will create an error response in cases where incorrect values are included. In the future, the expected values for these may change, so the XSD still allows them to validate against and errors will be thrown by the system during parsing.

CALLBACKS

The GSCCCA offers the use of callbacks – that is calling a SOAP web method set up by a filer upon change in status of a filing that user submitted. If a ReturnURL is given in the XML, then the system will attempt to perform a callback when the UCC is accepted or rejected. For further details, please see the UCC API Filer Implementation Guide on the Implementer's page here: <https://efile.gsccca.org/implementers.aspx>.

MAXIMUM PAYLOAD

Total maximum submission size is calculated including all submitted data, with XML size in bytes and UCC PDF size added together. With the XML data, the main contributor to document size when size is consequential will be the collateral attachment which is a base64 encoded string representing a PDF document. In cases where you include this attachment in the XML, ensure that its size summed with the submitted PDF do not exceed the maximum allowed size set by the Submit() web method in the UCCService.asmx service.

The current maximum payload is 10 Megabytes.